

Unicase

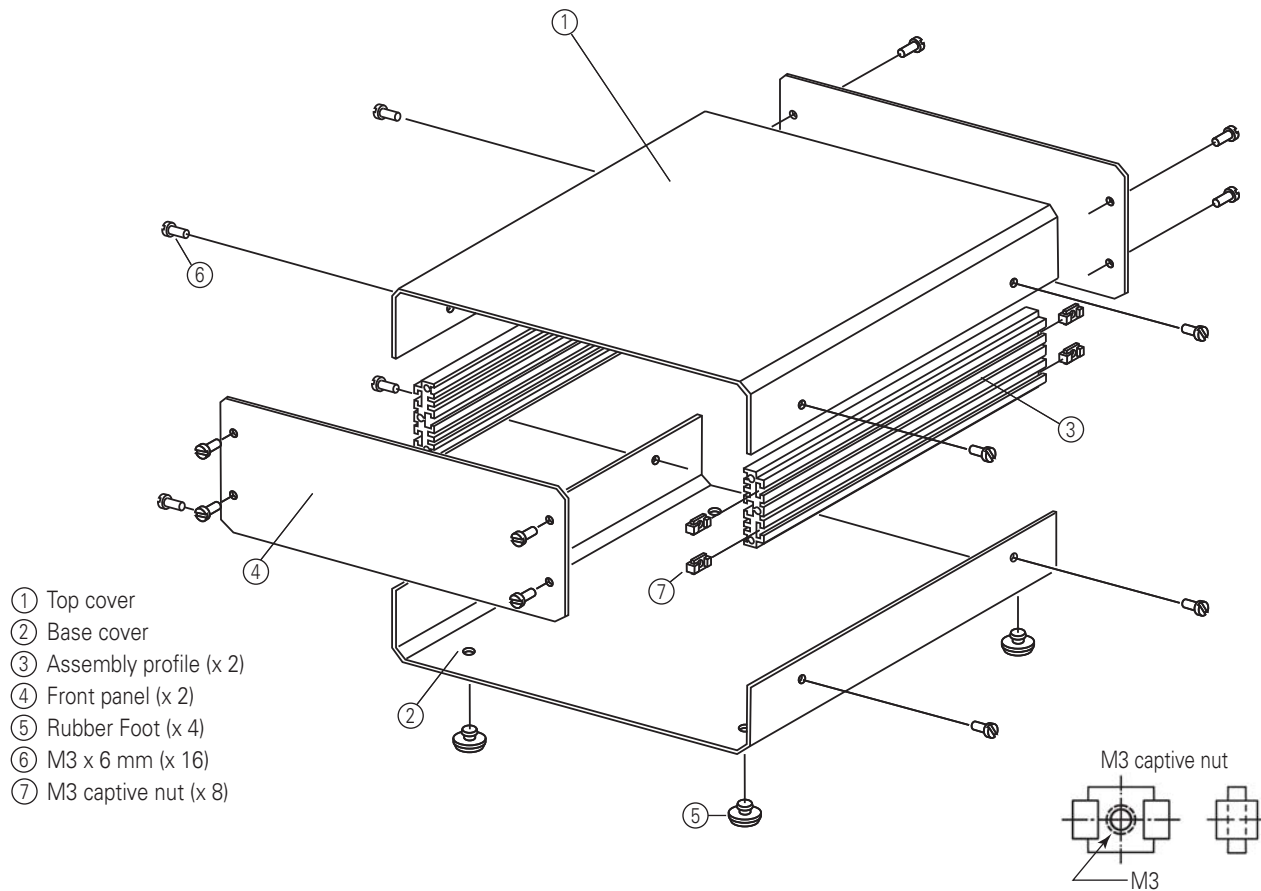

- ① Top cover
- ② Base cover
- ③ Assembly profile (x 2)
- ④ Front panel (x 2)
- ⑤ Rubber Foot (x 4)
- ⑥ M3 x 6 mm (x 16)
- ⑦ M3 captive nut (x 8)

Grey RAL 7035 Lichtgrau/Gris clair

Part No. Bestell-Nr./Réf.	Version
M 55 01 110	Unicase 1
M 55 02 110	Unicase 2
M 55 03 110	Unicase 3
M 55 04 110	Unicase 4
M 55 05 110	Unicase 5
M 55 06 110	Unicase 6

Black RAL 9005 Schwarz/Noir

Part No. Bestell-Nr./Réf.	Version	Part No. Bestell-Nr./Réf.	Version
M 55 11 110	Unicase SL1	M 55 11 119	Unicase SL1
M 55 12 110	Unicase SL2	M 55 12 119	Unicase SL2
M 55 13 110	Unicase SL3	M 55 13 119	Unicase SL3
M 55 14 110	Unicase SL4	M 55 14 119	Unicase SL4

Assembly Procedure

1. Insert four rubber feet into case bottom.
2. Insert eight M3 captive nuts into the two assembly profiles.
3. Secure the two assembly profiles to the case bottom using four of the M3 x 6 screws (fastening to the captive nuts).
4. Secure the case top to the assembly profile as per step 3.
5. Secure the front panels using the remaining M3 x 6 screws (fastening to the front and rear of the assembly profiles).

The case is now ready for use.